

SMARTSIDE®

TRIM & SIDING

PRECISION SERIES 3/8"-7/16" PRIMED LAP SIDING
GENERAL

- At the time of manufacture, siding meets or exceeds the performance standards set forth in ICC-ES-AC321 and has achieved code recognition under ES Report ESR-1301 and HUD recognition under HUD-UM-40C. For copies of AC321, contact the ICC-ES-AC321 at (562) 699-0543 or go online at http://www.icc-es.org/criteria/pdf_files/ac321.pdf. For copies of ESR-1301, call LP Customer Support at 1-800-648-6893 or go online at http://www.icc-es.org/reports/pdf_files?ICC-ES/ESR-1301.pdf.
- Apply siding in a manner that prevents moisture intrusion and water buildup.
- All exposed wood substrate must be primed and painted in a manner that prevents moisture intrusion and water buildup.

STORAGE

- Store off the ground, on a flat surface, under a roof or separate waterproof covering.
- Keep siding clean and dry. Inspect prior to application.
- Allow siding to adjust to atmospheric conditions before application.

STUD SPACING

- Space studs no farther apart than the span rating indicated on the product trademark.
- Precision Series 3/8" lap may be installed up to 16" OC framing spans. Precision Series 7/16" lap may be installed up to 24" OC framing spans.

MOISTURE

- Moisture control and moisture vapor control are critical elements of proper housing design. Check your local building codes for application procedures for handling moisture and moisture vapor in your area.
- As with all wood products, do not apply engineered wood siding to a structure having excessive moisture conditions such as drying concrete or plaster. If such conditions exist, the building should be well ventilated to allow it to dry prior to the application of the siding.
- Siding must not be applied to green or crooked structural framing members. Do not apply siding over rain-soaked or buckled sheathing materials.
- Gutters are recommended for control of roof water run off.

VAPOR RETARDER/WEATHER BARRIER

- A properly installed breathable water-resistive barrier is required behind the siding.
- Consult your local building code for details.
- LP will assume no responsibility for water penetration.

GAPS & SEALANTS

- Seal all gaps with a high-quality, non-hardening, paintable sealant with a minimum stated service life of 30 years. Follow the sealant manufacturer's instructions for application.

FLASHING, WINDOWS, DOORS & OPENINGS

- All openings must be properly sealed or flashed in a manner that prevents moisture intrusion or buildup. Several examples that accomplish this are shown on the following pages.
- Siding applied adjacent to porches, patios, walks, etc. must have a clearance of at least 1" above any surface. The surface must be sloped or otherwise designed to provide proper drainage so the siding is at no time directly exposed to standing water.

TRIM

- Trim should be thick enough so the siding does not extend beyond the face of the trim.
- Trim and fascia must be applied in a manner that will not allow moisture intrusion or water buildup.
 - LP® SmartSide® Lap siding and LP SmartSide Panel siding are not designed and/or manufactured to be used as trim or fascia. LP SmartSide trim and fascia are available in a variety of dimensions.

FINISHING INSTRUCTIONS
DO

- Priming all exposed wood substrates before painting is highly recommended.
- Paint all exposed siding surfaces including drip edges.
- Thoroughly paint the bottom edges of siding especially all cut ends next to the roof line.
- Apply paint as soon as possible and within 180 days of application.
- Follow the coating manufacturer's application and maintenance instructions.
- High-quality acrylic latex paint, specially formulated for use on wood and engineered wood substrates, is highly recommended. Semi-gloss or satin finish oil or alkyd paints are acceptable. For flat alkyd paint, please check with the coating manufacturers for their recommendations for use on composite wood siding.

NOT RECOMMENDED:

- Semi-transparent stain.
- Shake and shingle paints.
- Vinyl-based resin formulas such as vinyl acetate, PVA, vinyl acetate/acrylic copolymer paints.

APPLICATION INSTRUCTIONS (CONT.)

NAILING INSTRUCTIONS

- LP SmartSide $7/16$ " lap siding may be attached directly to framing members spaced up to a maximum of 24 inches on center. $7/16$ " LP SmartSide Lap may also be applied over code-approved nailable sheathing.
- LP SmartSide $3/8$ " lap siding may be attached directly to framing members spaced up to a maximum of 16 inches on center. $3/8$ " LP SmartSide Lap may also be applied over a code-approved nailable sheathing.
- Siding joints should be staggered over successive courses. For installation with or without nailable sheathing, joints must occur over stud locations.
- Siding should be installed with top (blind) nailing, with the nails placed a minimum of $3/4$ " from either end. Siding may be face nailed as required.
- Overlap successive courses of siding a minimum of 1".
- Use minimum 8d, corrosion resistant, box style nails.
- All exposed face nails must be caulked and sealed in a manner that prevents moisture intrusion and water buildup.
- Fasteners at each stud location must penetrate solid wood framing or the sheathing and wood framing a minimum of $1-1/2$ ".
- For information on fastening LP SmartSide Lap products in high wind speed areas, refer to ICC-ES Report ESR-1301.
- For application to structural insulated panels (SIPs), consult the SIPs manufacturer's recommendations for appropriate nailing instructions. Do not space the fasteners greater than the span rating located on the back of the panel.

CAUTION

- Do not force siding into place.
- Do not use staples.

OVERLAP, CLEARANCE & NAILING SPACE

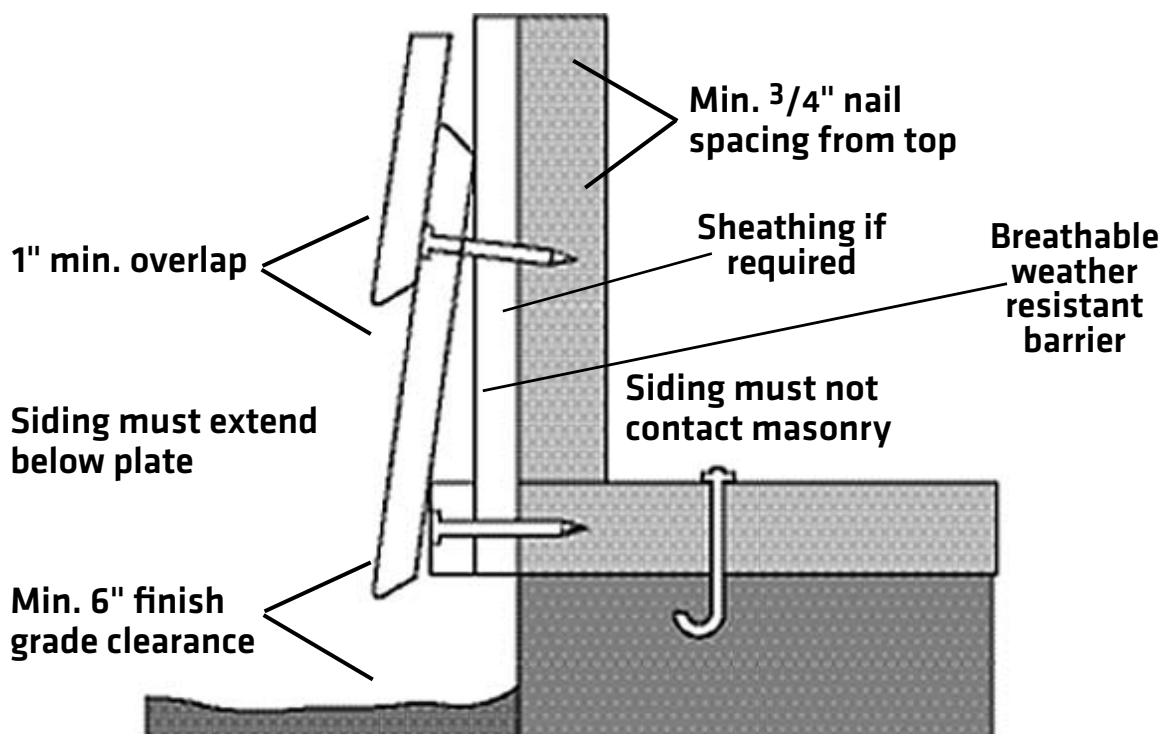

NOTE

IN HIGH MOISTURE CONDITIONS, SUCH AS THOSE ASSOCIATED WITH PACIFIC NORTHWEST, IT IS RECOMMENDED TO ACCLIMATE THE SIDING AT THE JOB SITE FOR 48 HOURS PRIOR TO INSTALLATION.

$3/16$ " GAP

Nail min. $3/4$ " from top and $3/8$ " from edge

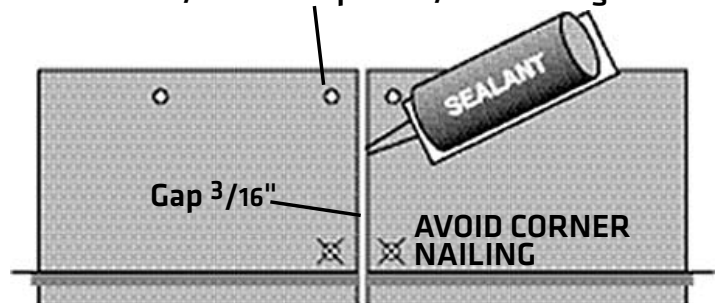

- A minimum $3/16$ " gap is required at butt joints.
- Seal all gaps at butt joints.
- Unsheathed walls require adequate bracing.
- Joints must occur over the studs.

over openings

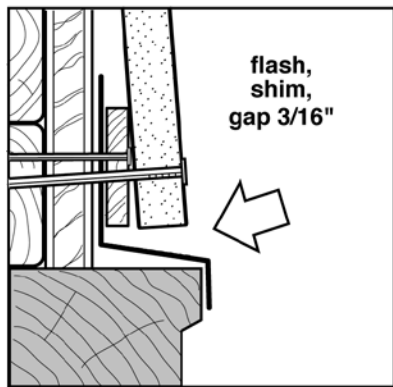

alternate joint treatment

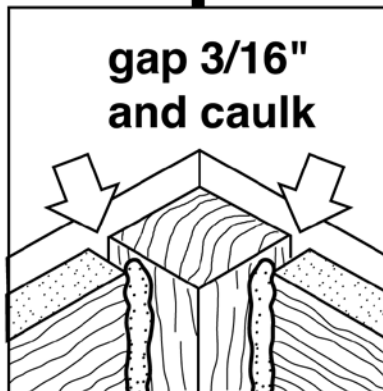
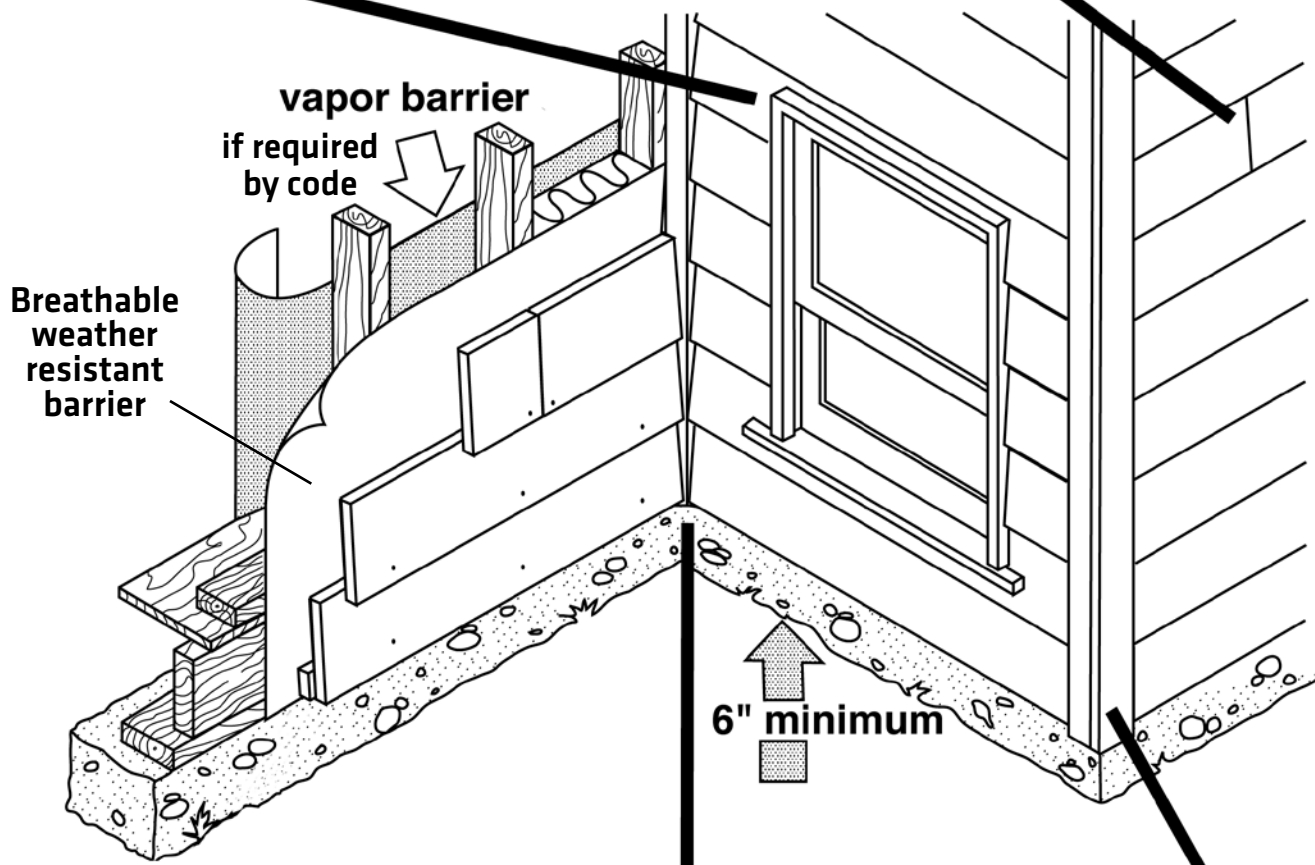
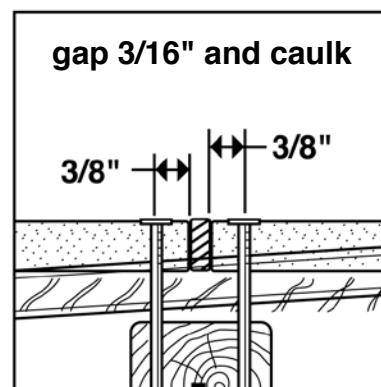
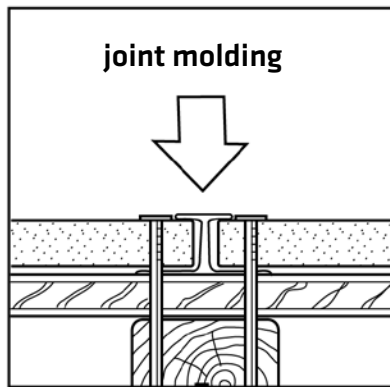

inside corner detail

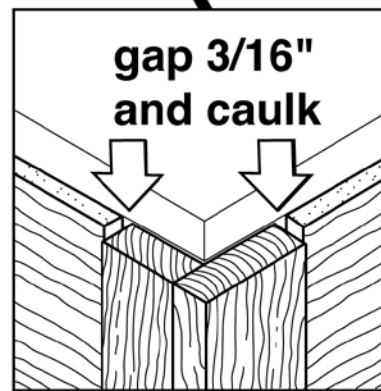

outside corner detail

BOTTOM COURSE DETAIL

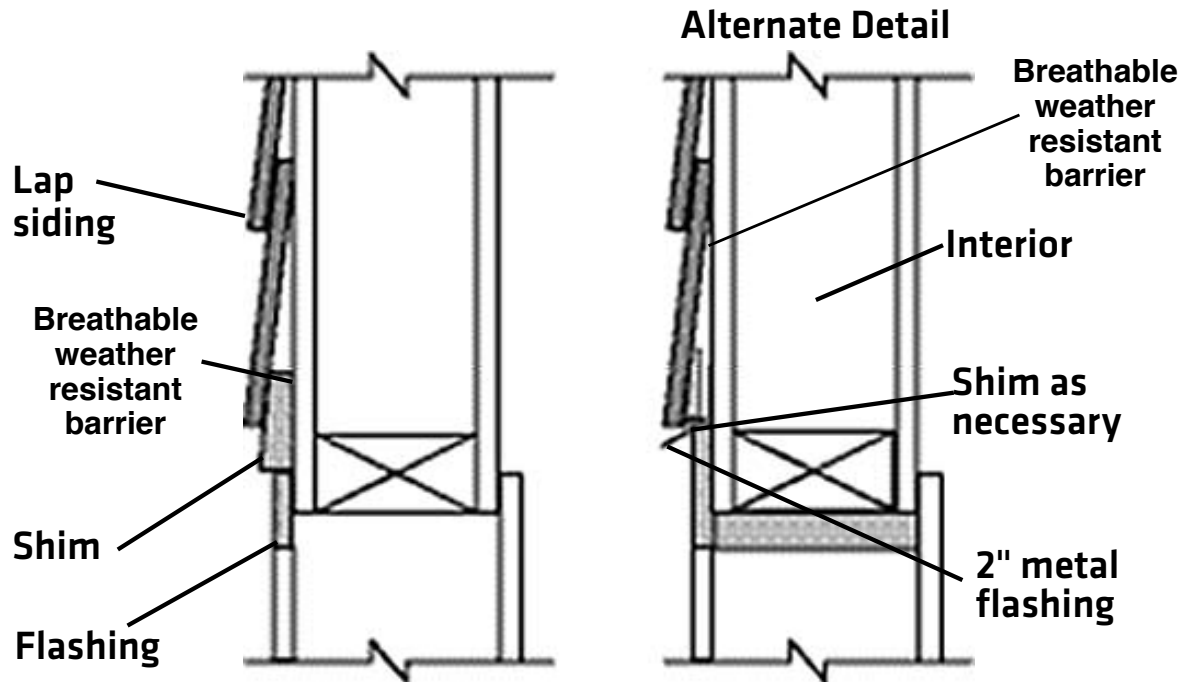

1" ROOF & CHIMNEY CLEARANCE

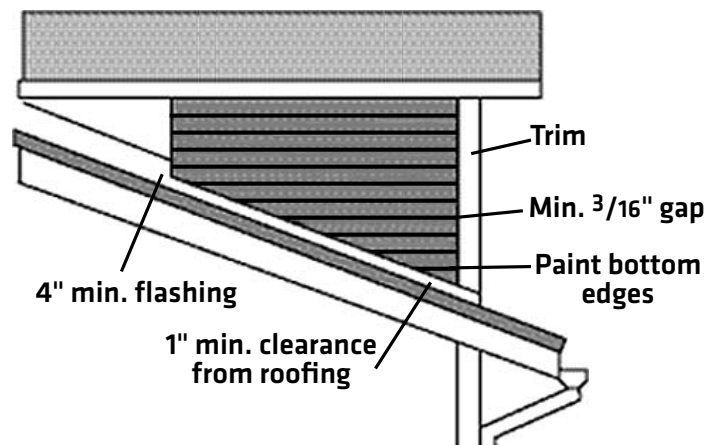

The Louisiana-Pacific Corporation ("LP") LP SmartSide Siding (the "Products") limited warranty (the "Warranty") applies only to structures on which the Products have been applied, finished and maintained in accordance with the published application, finishing and maintenance instructions in effect at the time of application. The failure to follow such application, finishing or maintenance instructions will void the Warranty as to the portion of the Products affected by the variance (the "Affected Products").

LP assumes no liability for any loss or damage sustained by the Affected Products and is expressly released by the purchaser or owner from any such loss or liability.

Any modification of the Warranty's application, finishing or maintenance requirements is void and unenforceable unless approved in writing prior to application by the Siding Business Manager or his designee and a member of the LP Legal Department.

For a copy of the warranty or for installation and technical support, visit the LP SmartSide product support Web site at:

www.lpcorp/smartside.com

or for additional support call 800.450.6106.

WARRANTY REMEDIES ARE NOT AVAILABLE IF REQUIREMENTS ARE NOT FOLLOWED.



© 2007 Louisiana-Pacific Corporation. All rights reserved. LP and SmartSide are registered trademarks of Louisiana-Pacific Corporation. Printed in U.S.A.

NOTE: Louisiana-Pacific Corporation periodically updates and revises its product information. To verify that this version is current, call 800-450-6106. LPZB0021