



SMARTSIDE® TRIM & SIDING

TRIM AND FASCIA 540 SERIES AND 440 SERIES

GENERAL

- There are no National Standards for wood composite substrate trim.
- LP SmartSide trim and fascia can be applied directly over materials such as siding, or nailed directly to structural members up to 24 in. O.C.
- Do not let trim contact masonry.
- Minimum 6 in. clearance must be maintained between trim and finish grade.
- Trim applied adjacent to porches, patios, walks, etc. must have a clearance of at least 1 in. above any surface where water might collect. The surface must be sloped or otherwise designed to provide proper drainage so the trim is at no time directly exposed to standing water.
- LP SmartSide trim and fascia are not designed for (a) siding; or (b) structural applications and should not be used as a structural member in construction such as a trellis, railing, fencing.
- A non-corrosive drip-edge or drip-cap must be applied at bottom edge of roofing where it meets the fascia.
- Trim and fascia must not be applied to green or crooked structural framing members. Do not apply trim and/or fascia over rain soaked or buckled sheathing materials.
- **DO NOT USE STAPLES**

STORAGE

- Store off the ground on a flat surface, under a roof or separate waterproof covering.
- Keep trim and fascia clean and dry. Inspect prior to application.
- Allow trim and fascia to adjust to atmospheric conditions before application.

MOISTURE

- Moisture control and moisture vapor control are critical elements of proper housing design. Check your local building codes for application procedures for handling moisture and moisture vapor in your area.
- Follow all applicable building code specifications relating to prevention of moisture intrusion into the wall assembly. LP SmartSide trim and fascia is a wood product, and, as with all wood products, must be kept free from constant sources of moisture. Lack of proper ventilation; exposure to repetitive sources of water such as sprinklers, condensation, inadequate flashing; improper sealing; or failure to follow common building practices that prevent moisture intrusion into the wall-system; may cause damage, and will void the warranty.

CUTTING

- For the cleanest cut and longer blade life, a fine-tooth carbide tipped blade is recommended.
- LP® SmartSide® trim and fascia are manufactured with a special edge coating which reduces moisture-related issues. Ripping and routing of the trim and fascia is not recommended, as it will leave the edges unprotected. If the trim or fascia materials are ripped and/or routed you must, take special care to prime, paint and seal all exposed wood fiber as described in the finishing section.

NAILING

- Use a minimum 8d, corrosion resistant (according to ASTM 641), box style nail, with a minimum 1/4 in. diameter head.
- Penetrate studs or studs and wood sheathing a combined 1".
- Leave 3/16 in. gap where trim butts into other materials and at butt joints, miter joints and ends. Where edges of trim meet siding material, windows, doors or other finished openings, leave a minimum 1/8" gap

NAILING (CONTINUED)

- to allow for proper sealing. Provide increased spacing along the trim if specified by the siding installation instructions.
- Leave 1 in. clearance between trim and roofing materials at roof rake.
- For edge-nailing, all nail holes must be pre-drilled. Do not attempt to edge-nail without pre-drilling.
- When applied as rake, corner or band board, nails must be spaced no further than 12 in. apart on alternating edges. Nails must be at least 3/8 in. from the edge.

CONDITION

CORRECTION

Snug		OK	
Flush		OK	
Visible fiber		Paint	
Countersunk 1/16-1/8 in.		Apply sealant	
Countersunk more than 1/8 in.		Apply sealant and re-nail	

FLASHING, WINDOWS, DOORS & OPENINGS

- All openings must be sealed and flashed in a manner that prevents moisture intrusion or water buildup. Several examples that accomplish this are shown.
- In a horizontal brick frieze or band board application where the trim overlaps the masonry leave a 3/16-inch minimum airspace or a layer of flashing between the trim and the masonry.

INSIDE CORNER DETAIL

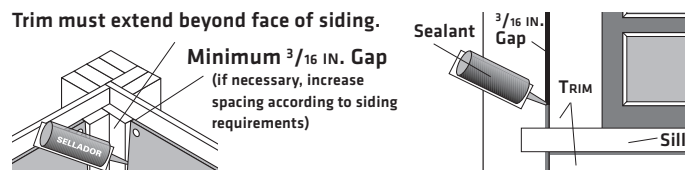

OUTSIDE CORNER DETAIL

Minimum 2 in. overlap space siding 3/16 in. from corner of wall

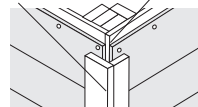

ALTERNATE OUTSIDE CORNER DETAIL

Trim must extend beyond face of siding.

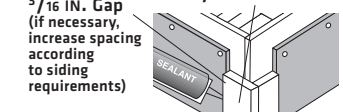

BUTT JOINT DETAIL

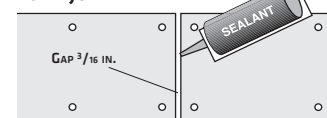

DOORS & WINDOWS

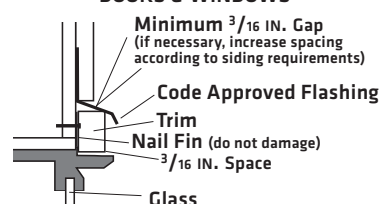

HORIZONTAL TRIM

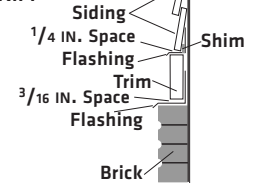

APPLICATION INSTRUCTIONS (CONT.)

GAPS, SEALANT & JOINTS

- Seal all gaps with a high-quality, non-hardening, paintable sealant with a minimum stated service life of 30 years. Follow the sealant manufacturer's instructions for application.

JOINT DETAIL

Joints where two trim ends meet may be handled in one of two methods:

- Ends must be spaced and joints may lightly touch in runs less than 16 feet. Butt joints require a 3/16 in. gap in runs over 16 feet. Seal with a good quality flexible long-life sealant. Butt joints require four (4) nails with two nails on either side of the joint at each edge.
- Scarf joints may be used without a gap in runs less than 16 feet. Trim joints require four (4) nails with two (2) nails either side of the joint at each edge.

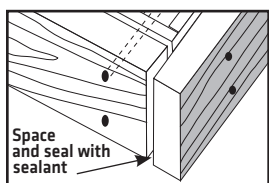

End-to-end joints in vertical trim should be installed so that they shed water.

Do not miter corner joints of band boards, fascia, etc. Allow the end of the trim to lap over the end of the adjoining trim and space 3/16 inch.

GABLE ENDS

- At gable ends, a backer board (such as a barge rafter) should be used under fascia to provide maximum support along the length of the product (see Diagram A).
- If LP SmartSide trim and fascia is installed directly to lookouts on an overhanging rake, the lookouts must be installed edgewise and must be spaced no wider than 24" O.C. (see Diagram B). THIS APPLICATION APPLIES TO MINIMUM 6" 540 SERIES STRAND TRIM ONLY.

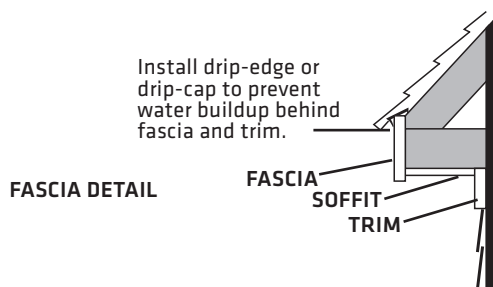
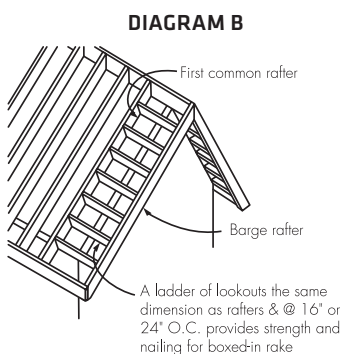
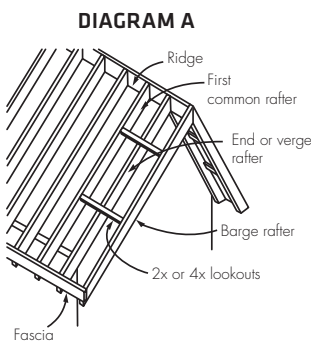

MITERING

- Do not miter trim edges. 45 degree mitering of trim ends around door and window openings is acceptable, as well as scarf joining.

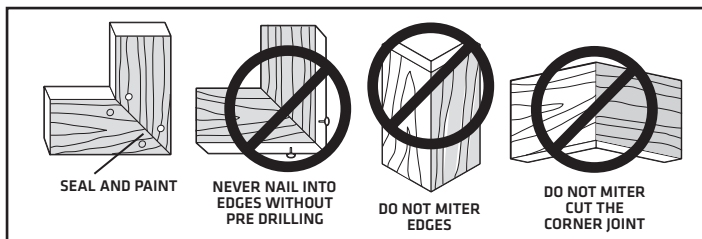

FASCIA AND RAKE BOARDS AT CORNERS

- Where framing members (rafters, hip rafters, etc.) are not located where pieces join, solid blocking should first be installed with the trim and then nailed to it. Do not nail from the face of one trim member into the edge of another. Do not miter cut the corner joint.

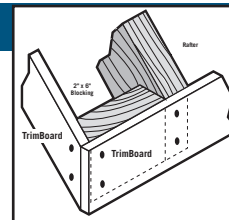

FINISHING

DO

- Prime and paint all exposed surfaces.
- Apply finish coat as soon as possible or within 180 days of application.
- High-quality acrylic latex paint, specially formulated for use on wood and engineered wood substrates, is highly recommended. Semi-gloss or satin finish oil or alkyd paints are acceptable. For flat alkyd paint, please check with the coating manufacturer for their recommendations for use on composite wood siding.
- Follow the coating manufacturer's application and maintenance instructions.

DO NOT USE

- Semi-transparent and transparent stains.
- Shake and shingle paints.
- Vinyl-based resin formulas such as vinyl acetate, PVA, vinyl acetate/acrylic copolymer paints.

The Louisiana-Pacific Corporation ("LP") LP SmartSide trim and fascia (the "Products") limited warranty (the "Warranty") applies only to structures on which the Products have been applied, finished and maintained in accordance with the published application, finishing and maintenance instructions in effect at the time of application. The failure to follow such application, finishing or maintenance instructions will void the Warranty as to the portion of the Products affected by the variance (the "Affected Products").

LP assumes no liability for any loss or damage sustained by the Affected Products and is expressly released by the purchaser or owner from any such loss or liability.

Any modification of the Warranty's application, finishing or maintenance requirements is void and unenforceable unless approved in writing prior to application by the Siding General Manager or his designee and a member of the LP Legal Department.

For a copy of the warranty or for installation and technical support, visit the LP SmartSide product support Web site at:

www.lpcorp.com

or for additional support call 800.450.6106.

WARRANTY REMEDIES ARE NOT AVAILABLE IF REQUIREMENTS ARE NOT FOLLOWED.



©2010 Louisiana-Pacific Corporation. All rights reserved. Printed in USA. LP and SmartSide are registered trademarks of Louisiana-Pacific.

NOTE: Louisiana-Pacific Corporation periodically updates and revises its product information. To verify that this version is current, call 800-450-6106. LPZB0521